

picoUPS-100

12V DC battery backup system
Micro UPS (uninterruptible power supply)

Quick Installation Guide

Version 1.0a
P/N picoUPS-100

Introduction

The picoUPS-100 is a small yet powerful UPS (uninterruptible power supply) solution. The picoUPS-100 was conveniently design to be compatible with quarter brick PSU standard (58 x 36mm).

The picoPSU-100 ensures uninterrupted power for your electronics by automatically switching in between a DC input source (15-18V) and a Lead Acid (SLA battery). The switching in between the power sources is instantaneous, thus allowing smooth, uninterrupted device operation. The picoUPS-100 also has a built-in, two stage battery charger unit.

Mode of Operation

The PICOUPS-100 has been specifically designed for uninterruptible small/medium power PC operation, where “always on” operating is required. Applications for the picoUPS include a wide range of systems including servers and telecom and high availability systems. These applications often have either N+1 redundant power supplies, redundant power buses, or both.

Fig 1.1 picoUPS block diagram

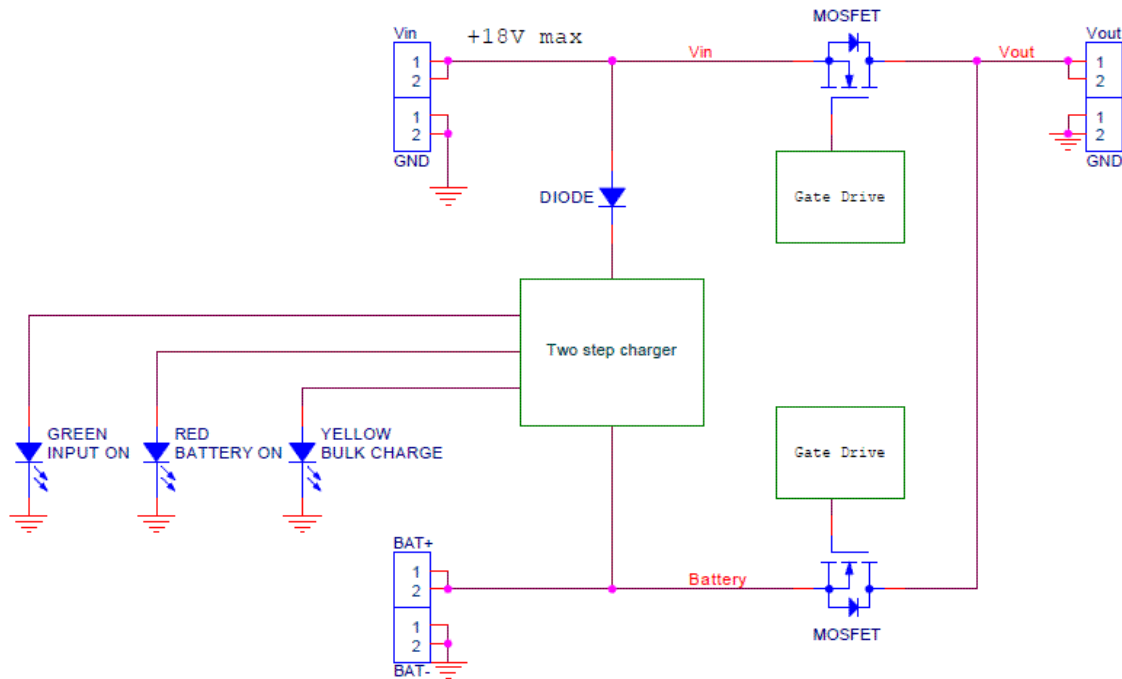

Power inputs

- 1) A 16V power source. The actual range for V(in) 15-18V.
NOTE: Unit will work as low as 6V, but battery will not be charged if V(in) is lower than 15V!
- 2) A Lead Acid or Sealed Lead Acid battery

Power Path Switching

The picoUPS-100 will automatically switch in between V(In) and Batt depending on who has a higher voltage. The switching hysteresis is as low as 10mv. As a result, when AC/DC power is lost, the picoUPS will automatically switch to Battery output. The switching speed is about 100nS.

Battery charging, bulk charging mode

The picoUPS-100 has a built in, two stage SLA battery charger. First stage is **bulk charging stage**, where the battery is being charged at a constant current of ~500mA. Depending on battery size and level of discharge, bulk charging stage can be anywhere from few minutes to few hours. For example, a typical 7AH / 12V SLA battery will fully charge in 6-12 hours. During this time the Orange LED will be ON.

Battery charging, float charging mode

When the battery is near full capacity, charge current will slowly decrease. At this point, picoUPS will switch charging mode from bulk to **float charge**. Float charging ensures that the battery is kept at a precise 13.5V.

Typical configuration

A typical configuration for a low / medium power computer setup is comprised from a 12V / 7Ah battery, a 16V / 5A AC/DC adapter. The output can be coupled to ATX power supply such as M1-ATX, M2-ATX, M3-ATX or picoPSU-60-WI or picoPSU-120-25.

Specifications, picoUPS-100.

Power Ratings (max load = 10A)

Volts (V)	Max Load (A)	Peak Load (A)	Bulk Charge
6-18V*	6A	10A	500mA

* if Vcc is below 15V unit will work but will not charge the Battery.

Precautions for operating this DC-DC converter:

-For fanless operation de-rate the output of the 3.3 and 5V rails by ~35% or ensure PSU surface temperature should not exceed 65C, whichever comes first.

-Input current should not exceed 20A.

-Peak load should not exceed 60 seconds.

-Float voltage is 13.5V (+/- 1%)

Green LED: V(in) is active. V(in) is routed to V(out).

Red LED: Batt is active. Batt is routed to V(Out).

Orange LED: Batt is in bulk charging mode.

Input Requirements: 16V regulated, min=2A, max = load dependent.

Size: 58mm(L) * 36mm(W) * 20mm (H) (1U compliant)

Weight: 30gramms

Connectors: Faston Blades, 0.187'

LED: 0603 status LEDs (Vcc, BATT, Charge)**Overload protection**

This unit does not provide overload protection. Inrush current should not exceed more than 20A for 1 second.

Operating environment

Temperature: -20 to 65 degree centigrade.

NOTE: For fanless operation, please ensure that the PSU body temperature, T(psu) does not exceed 75C. Higher temperatures are allowed, but MTBF could decrease. Maximum power supply body temperature T(psu) is 85C.

Relative Humidity: 10 to 90 percent, non-condensing.

Efficiency, MTBF: 95%. MTBF=100K hours at T(psu) 55Celsius.

Shipping and storage

Temperature -40 to +40 degree centigrade. Relative humidity 5 to 90 percent, non-condensing

Warranty

1 Year Limited Warranty statement. Warranty is void if maintenance or calibration is performed by end-user or by use in conjunction with power modules not provided by mini-box.com.

Support

Web Site: <http://www.mini-box.com/site/support.html>